

HERRAJES DE ANDALUCÍA



SEVILLA

Avda. de la Industria 15
Polg. Ind. Carretera Amarilla 41 007 SEVILLA
Tlf. 95 499 85 40
e-mail: info@herrajesandalucia.com
 690 866 531

ALMERÍA

C/ Sierra de Atalaya 19
Polg. Ind. La Jualda 04240 Viator ALMERÍA
Tlf. 950 30 60 98
e-mail: info@herrajesandalucia.com
 660 671 845

www.herrajesandalucia.com

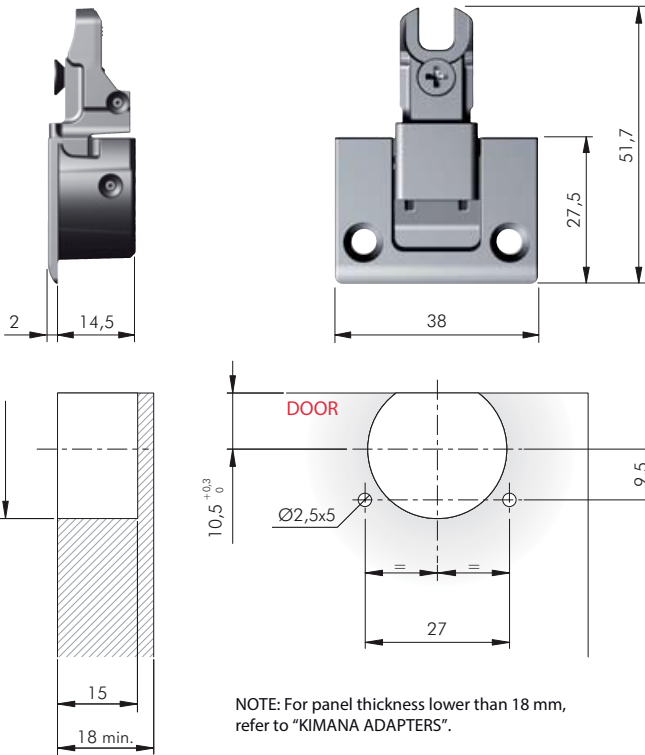
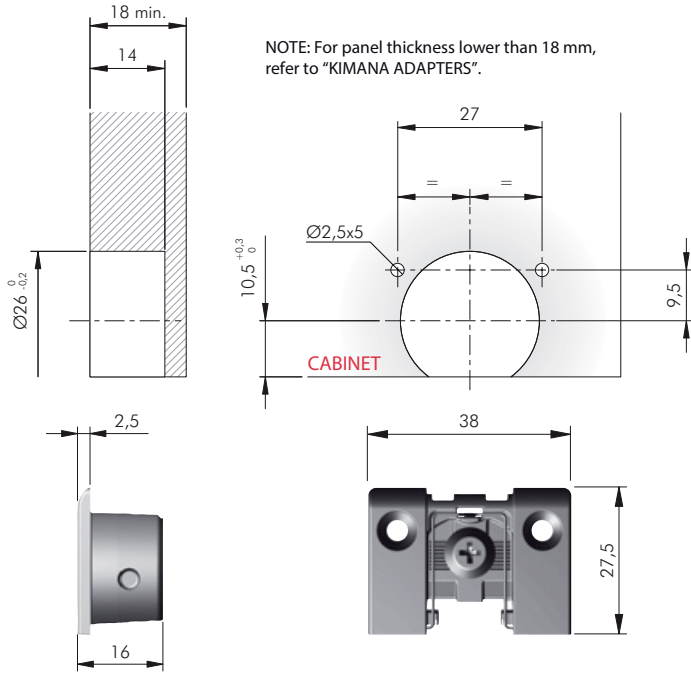

		= 150 pcs.
ZA	ST	
C010000881	Cod. 03654	

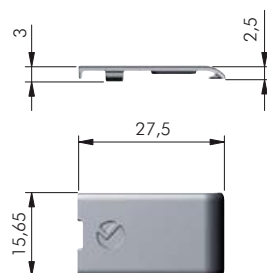

COMPACT 164 mm - LIFT UP - Friction version

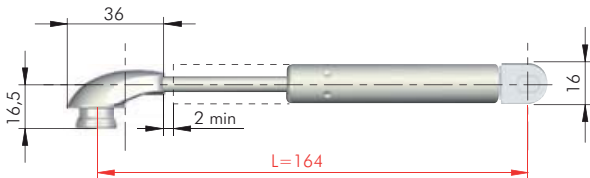

ZAnk EP ST

= 100 pcs.



42302010 NN

60

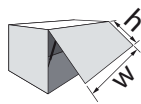

h	w	450		600		900		1200	
		Kg	Compact	Kg	Compact	Kg	Compact	Kg	Compact
230-250		1,2 - 1,3	1 x 45 N	1,6 - 1,8	1 x 45 N	2,4 - 2,6	2 x 45 N	3,2 - 3,5	2 x 45 N
251-300		1,3 - 1,6	1 x 45 N	1,8 - 2,1	2 x 45 N	2,6 - 3,2	2 x 45 N	3,5 - 4,2	2 x 60 N

Further newton strengths available on request.

The above chart refers to chipboard or MDF 18 mm doors and aluminium frame doors with glass 4 mm thick. These are experimental results to be checked by the customer. Our Technical Department is at your disposal to test further cases out of this chart

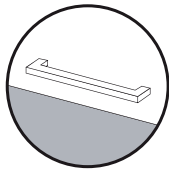
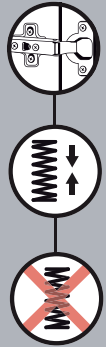

	α°
Side bracket in Position A	88°
Side bracket in Position B	71°

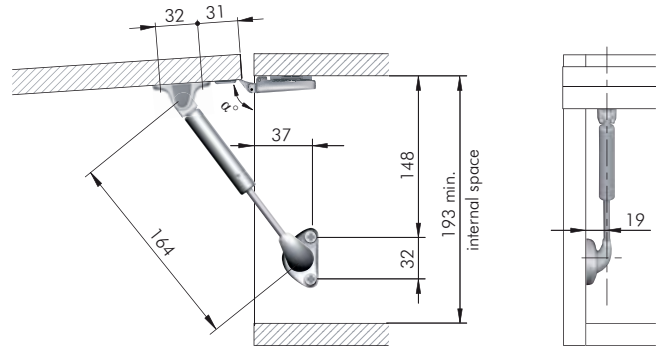

The dimensions of the above drilling plan refer to carcasses which use **standard sprung or unsprung hinges** and mounting plates 0 mm. Please note that α° opening angle shown data is purely indicative. It varies with respect to the hinge brand and adjustment carried out.

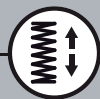
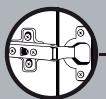

Please note that in case of use of **negative hinges**, **magnet K Lock** is required. For details refer to section "PUSH CATCHES & MAGNETIC CATCHES".

COMPACT 244 mm - LIFT UP - Friction version

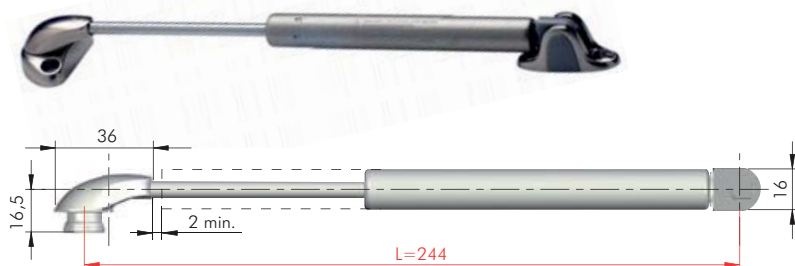

ZAnk EP ST

= 100 pcs.



42312010 NN

60

42313010 NN

90

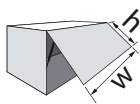

h	W	450		600		900		1200		1500	
		Kg	Compact	Kg	Compact	Kg	Compact	Kg	Compact	Kg	Compact
300-350	1,6 - 1,8	1 x 45 N	2,1 - 2,5	1 x 60 N	3,2 - 3,7	1 x 90 N	4,2 - 4,9	2 x 45 N	5,3 - 6,1	2 x 60 N	
351-400	1,8 - 2,1	1 x 45 N	2,5 - 2,8	1 x 60 N	3,7 - 4,2	2 x 45 N	4,9 - 5,6	2 x 60 N	6,1 - 7,0	2 x 90 N	
401-450	2,1 - 2,4	1 x 60 N	2,8 - 3,2	2 x 45 N	4,2 - 4,7	2 x 60 N	5,6 - 6,3	2 x 90 N	7,0 - 7,9	2 x 90 N	
451-500	2,4 - 2,6	2 x 45 N	3,2 - 3,5	2 x 60 N	4,7 - 5,3	2 x 60 N	6,3 - 7,0	2 x 120 N			
501-550	2,6 - 2,9	2 x 45 N	3,5 - 3,9	2 x 60 N	5,3 - 5,8	2 x 90 N	7,0 - 7,7	2 x 120 N			

Further newton strengths available on request.

The above chart refers to chipboard or MDF 18 mm doors and aluminium frame doors with glass 4 mm thick. These are experimental results to be checked by the customer. Our Technical Department is at your disposal to test further cases out of this chart

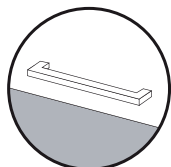
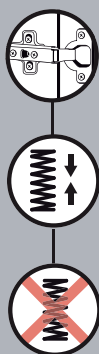

	α°
Side bracket in Position A	86°
Side bracket in Position B	78°

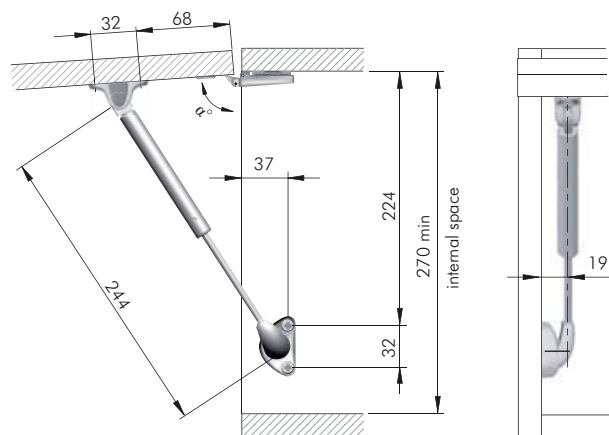

The dimensions of the above drilling plan refer to carcasses which use **standard sprung or unsprung hinges** and mounting plates 0 mm. Please note that α° opening angle shown data is purely indicative. It varies with respect to the hinge brand and adjustment carried out.

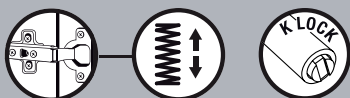

Please note that in case of use of **negative hinges**, **magnet KLock** is required. For details refer to section "PUSH CATCHES & MAGNETIC CATCHES".

COMPACT 244 mm - DROP DOWN



ZAnk EP ST = 100 pcs.

42510010 NN 0

h	W	1200 max.
301-350	2xL 244mm	< 4,9 Kg

This chart refers to chipboard or MDF 18 mm doors and aluminium frame doors with glass 4 mm thick using standard, flap or Kimana hinges. These are experimental results to be checked by the customer. **In accordance with the actual European regulation, we suggest to use at least two stays for each door (extra-size doors might require 3 or more gas stays).** For doors whose weights/dimensions are bigger than those reported on the chart, please increase the number of stays accordingly. Please make sure that gas stays are properly regulated in height through the apposite rotary knob so that the weight of the door is equally distributed amongst the stays used. Our technical department is at your disposal to test further cases out of this chart

	α°
Side bracket in Position A	86°
Side bracket in Position B	78°

The dimensions of the drilling plan refer to carcasses which use **standard sprung hinges** and mounting plates 0 mm.
Please note that α° opening angle shown data is purely indicative. It varies with respect to the hinge brand and adjustment carried out.

Please note that in case of use of **unsprung hinges** or **negative hinges**, **magnet K Lock** is required. For details refer to section "PUSH CATCHES & MAGNETIC CATCHES".



COMPACT BRACKETS

recommended fixing countersunk head wood screw $\varnothing 4 \times 18$ mm

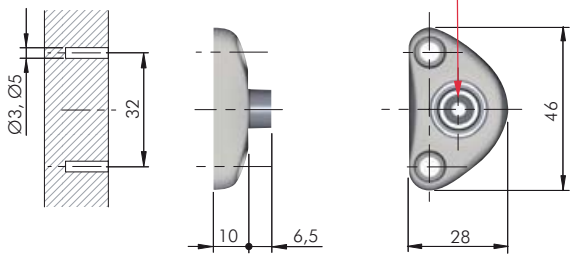

= $\varnothing 3, \varnothing 5$ mm

ZA EP

= 100 pcs.



42911010 YA

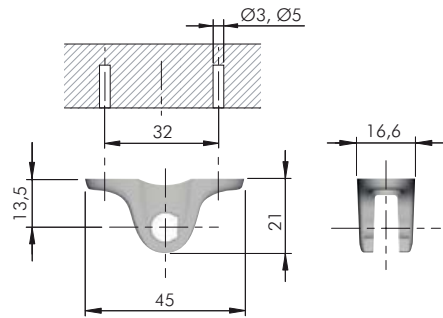

= $\varnothing 3, \varnothing 5$ mm

ZA

= 100 pcs.



42918010 YC

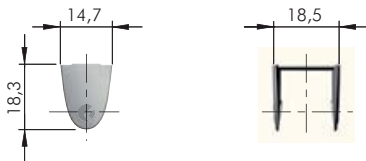

EPg

= 100 pcs.



42919010 00

K12 SYSTEM 244 mm - LIFT UP - Automatic version

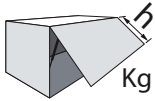
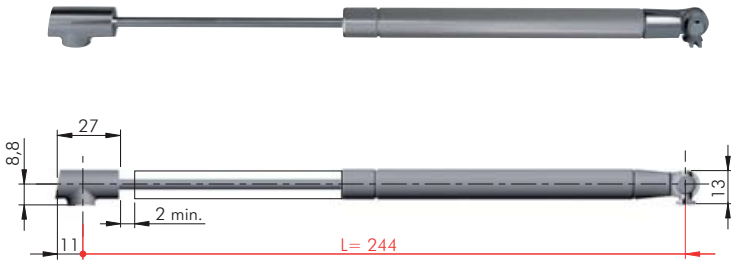

ZAnk	EP	ST	= 50 pcs.
		N	
48020460 UZ		80	
48020480 UZ		100	
48020500 UZ		120	

Rev.01

h	Door weight (Kg)																																	
	1	1,5	2	2,5	3	3,5	4	4,5	5	5,5	6	6,5	7	7,5	8	8,5	9	9,5	10	10,5	11	11,5	12	12,5	13	13,5	14	14,5	15	15,5	16	16,5	17	17,5
300	1 x 50N	1 x 80N	2 x 50N	2 x 80N				2 x 100N				2 x 120N		2 x 140N		2 x 160N		2 x 180N			3 x 140N		3 x 160N											
350	1 x 50N	1 x 80N	2 x 50N	2 x 80N				2 x 100N		2 x 120N		2 x 140N		2 x 160N		2 x 180N				3 x 140N			3 x 160N											
400	1 x 50N	1 x 80N	2 x 50N	2 x 80N		2 x 100N		2 x 120N		2 x 140N		2 x 160N		2 x 180N				3 x 140N			3 x 160N													
450	1 x 50N	2 x 50N		2 x 80N		2 x 100N		2 x 120N		2 x 140N		2 x 160N		2 x 180N		3 x 160N		3 x 180N		4 x 160N		4 x 180N												
500	1 x 50N	2 x 50N		2 x 80N		2 x 100N		2 x 120N		2 x 140N		2 x 160N		2 x 180N		3 x 160N			3 x 180N		4 x 160N		4 x 180N											

These are experimental results to be checked by the customer. Our Technical Department is at your disposal to test further cases out of this chart.

BRACKETS Ø15:

SCREW FIXING BRACKETS:

The dimensions of the above drilling plan refer to carcasses which use **standard sprung or unsprung hinges** and mounting plates 0 mm. Please note that the opening angle shown data is purely indicative. It varies with respect to the hinge brand and adjustment carried out.

Please note that in case of use of **unsprung or negative hinges**, **magnet K Lock** is required. For details refer to section "PUSH CATCHES & MAGNETIC CATCHES".



K12 SYSTEM BRACKETS

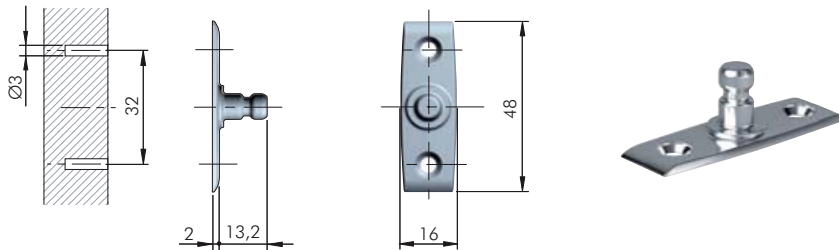



 = Ø 3 mm

ZA

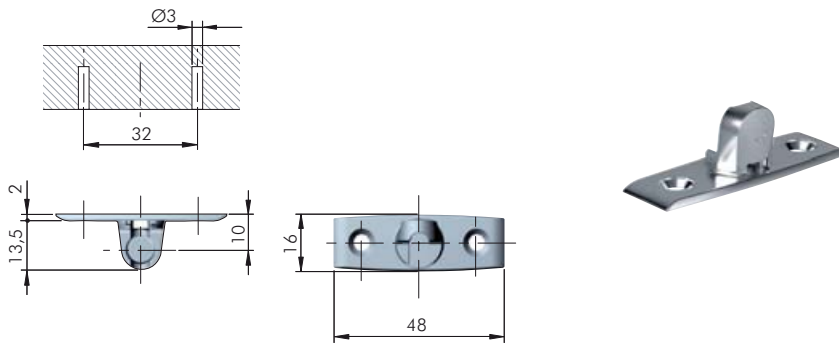

48080120 YA



 = Ø 3 mm

ZA



48080100 YA

KALABRONE

Glass, wood and honeycomb shelves

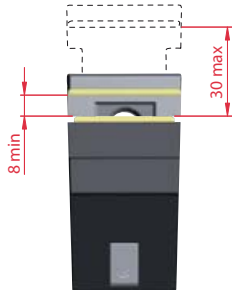

Shelf is clamped between a layer of ridged plastic on the lower side and soft rubber on the upper side (coloured parts).

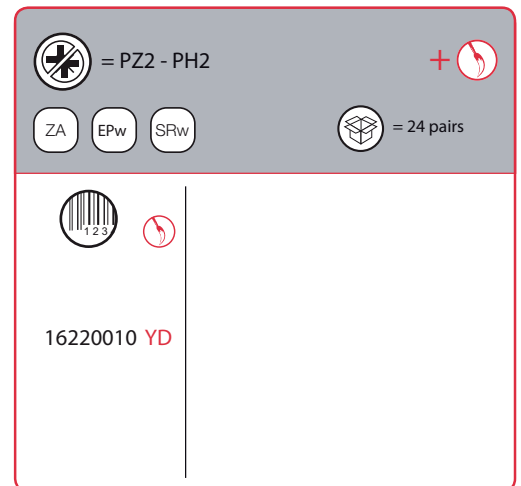
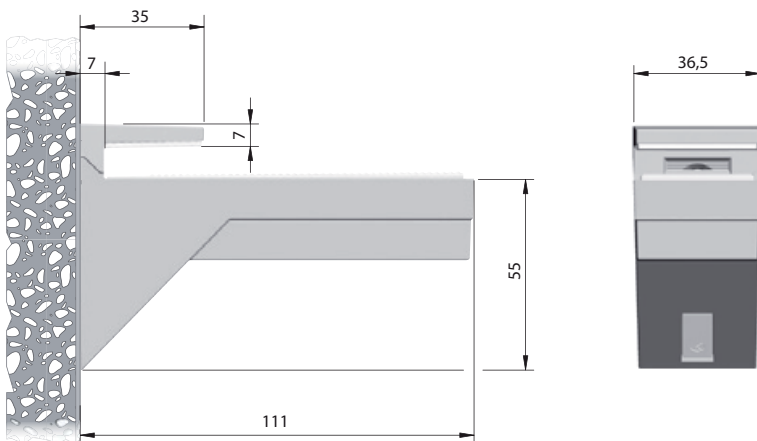

NOTE: KALABRONE is supplied in carton box including 2 pieces, accessories and fitting guide. Fixing screws to wall not included.



KALABRONE MINI



5-10 mm

6 kg for each shelf support for shelf 150 mm deep

REGISTERED DESIGN

INSTALLATION AND ADJUSTMENTS

WOOD PANEL

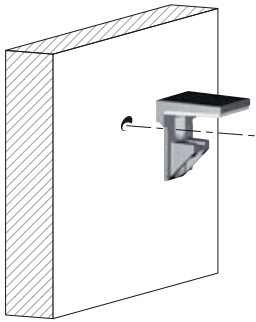

Recommended fixing countersunk screw type - head Ø 5 mm max.

SOLID AND PLASTERBOARD WALLS

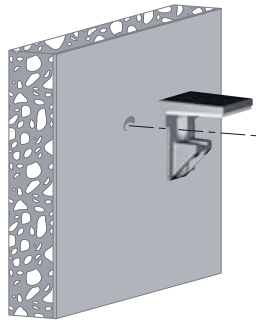

It is the responsibility of the customer:
 - to ensure that the wall is of a suitable quality to hold the shelf fixing in place.
 - to use the proper hardware fittings according to the construction of the wall.
 For more specific information, please refer to the WARNINGS section at the end of the catalogue.

BRACKET ALIGNMENT

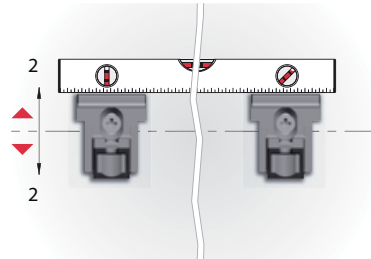

Glass shelves

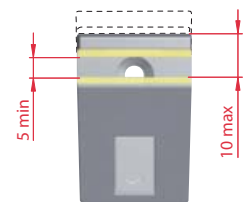

Shelf is clamped between a layer of white soft rubber on both the lower and upper side (coloured parts).

SHELF LOCKING

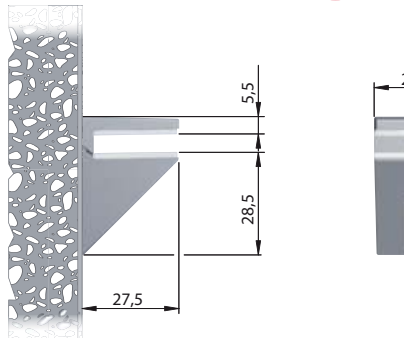
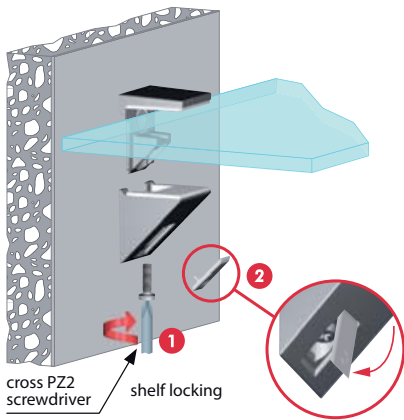

COMBINATION SHELF LOAD AND SHELF DEPTH

(The figures refer to 1 shelf support)

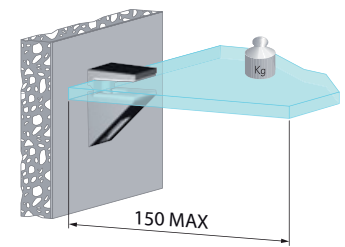
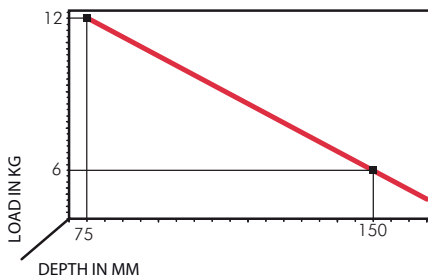

+ shelf weight = 6 kg MAX for each shelf support

Note: KALABRONE MINI is supplied individually bagged with fitting guide.

= PZ2

= 100 pcs.

16220080 YD



PEKI

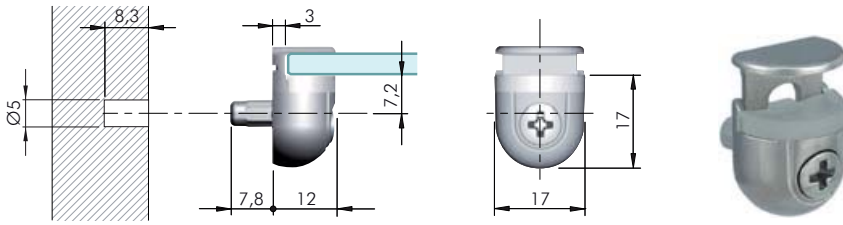





Technical specifications and packaging information for the PEKI glass shelf support:

- = Ø 5 mm
- = PZ2
- ZA SRn
- = 1000 pcs.

Barcode: 16013040 YA

TRIADE



 = PZ2	 = open ended wrench 10 mm
ZA	ST
	 = 50 pcs.
16215010 00	Cod: 10767

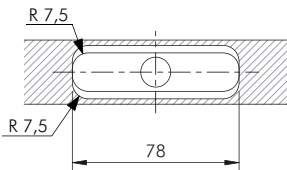
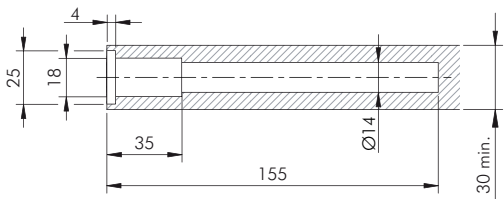
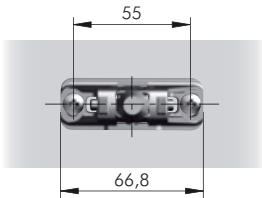
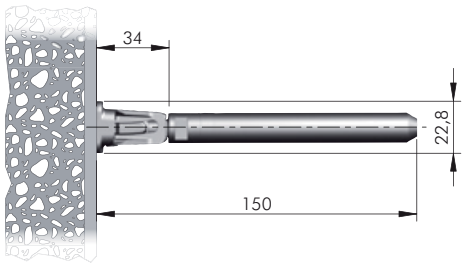



K LINE

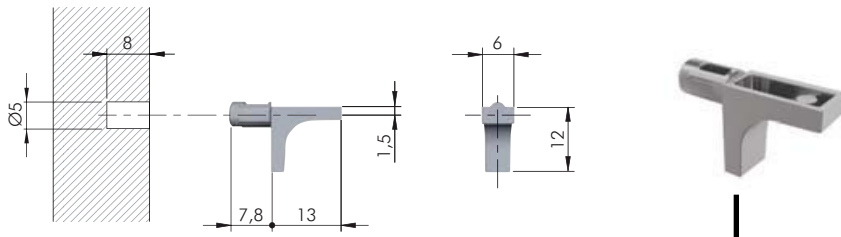

Conjunto Cod. 10778

= Ø 5 mm	+
ZA	= 5 000 pcs.
123	
10208020 YA	

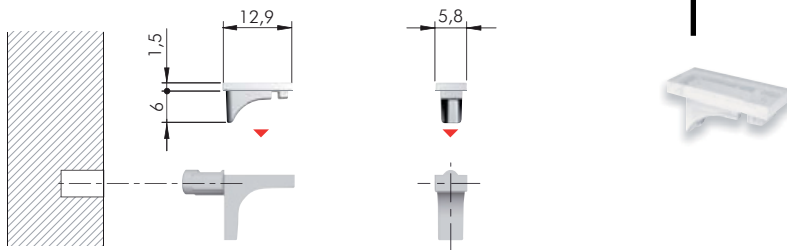

	+
SRn	= on request
123	
10208060 AA	

OR

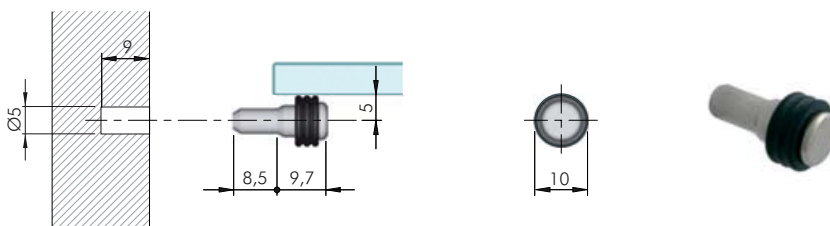

= Ø 5 mm	+
ST SRb	= 5000 pcs.
123	
16001020 YA	

ELEFANT: APPLICATION FOR SIDE PANEL

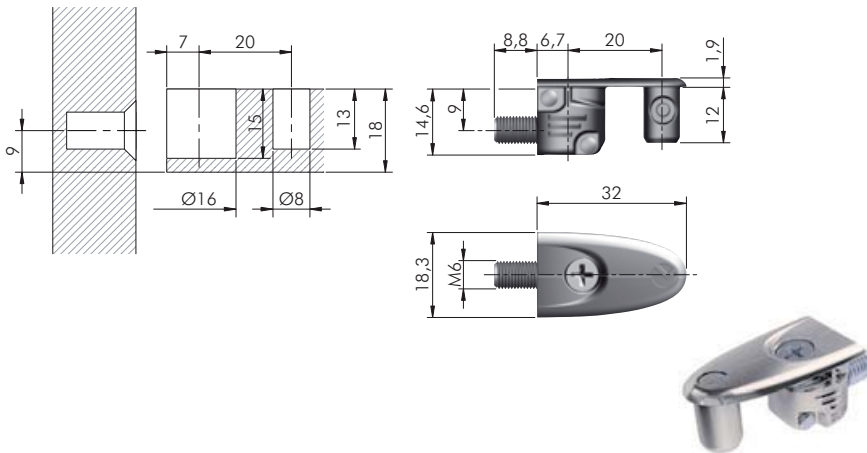

= 18 mm	= PZ2	= M6
ZA	ST	= 1000 pcs.
11901010 YA	Cod. 10774	

ELEFANT FIXING ACCESSORY FOR SIDE PANEL

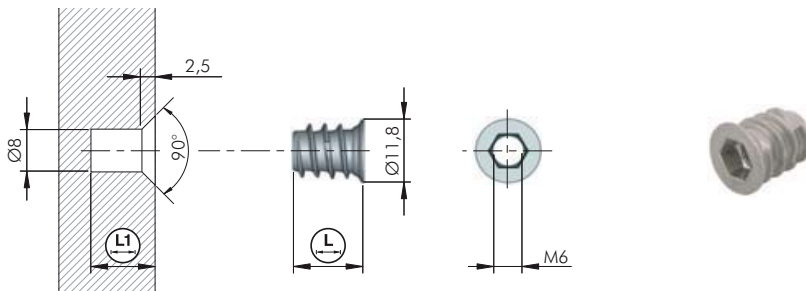

= Ø 8 mm	= M6	
	= S6	= 5000 pcs.
ZA	L	L1
20102020 GR	13	15
Cod. 10777		

ELEFANT: APPLICATION FOR PARTITION 18 - 19 mm THICK

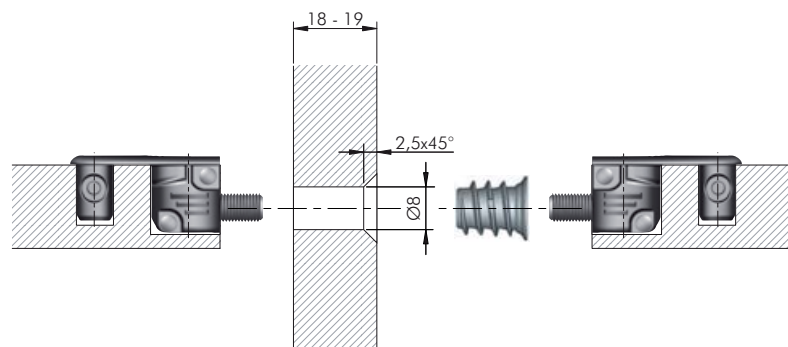



FLIPPER

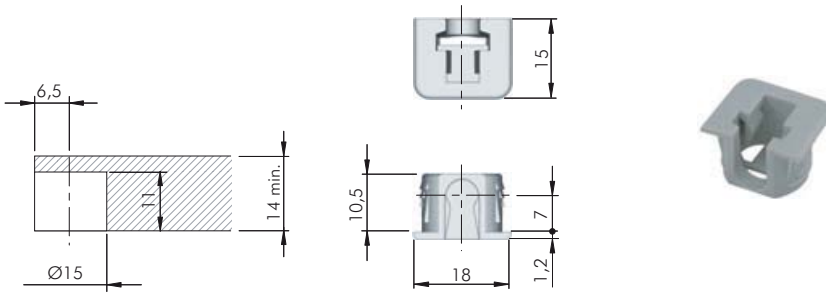

= 14 mm	+
EP	= 10.000 pcs.
10601020 JG	Cod. 03660

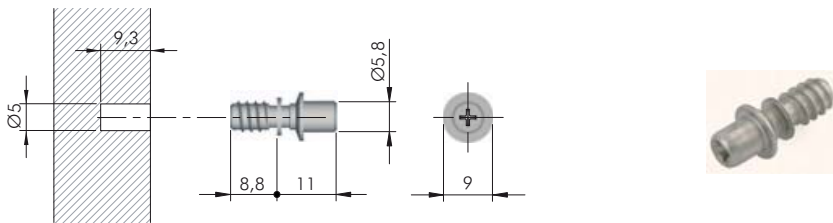

= Ø 5 mm	
= PZ2	
ST	= 2500 pcs.
10604010 ZN	Cod. 03661

FLIPPER

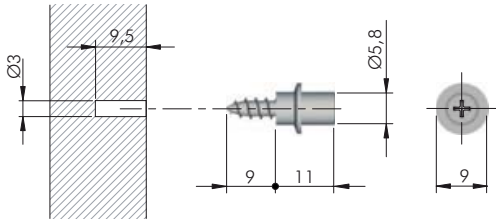

= Ø 3 mm

= PZ2

ST

= 6000 pcs.



10603010 ZN

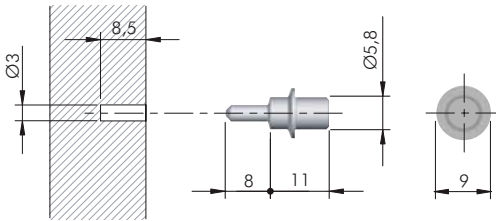

= Ø 3 mm

ST

= 5000 pcs.



10605030 ZN

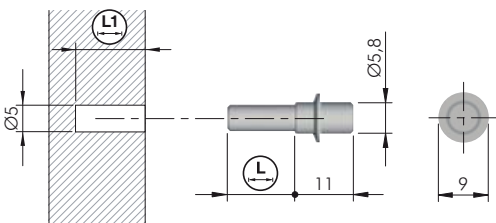

= Ø 5 mm

ST



10605020 ZN



12,5



13



3500

10605010 ZN

8,5

9

3000

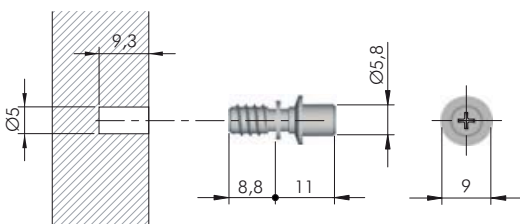

= Ø 5 mm

= PZ2

ST

= 2500 pcs.



10604010 ZN

Cod. 03661



SHELF SUPPORTS

PK2  16 mm

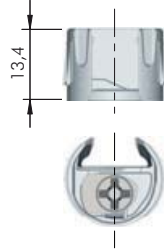
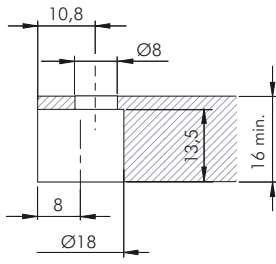

= PZ2



ZA



EP



= 2500 pcs.



11401010 IJ

Cod. 10769

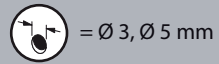
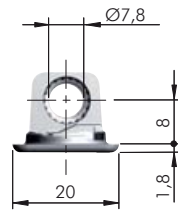
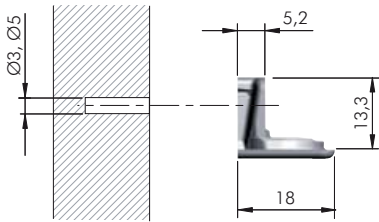

= Ø 3, Ø 5 mm



ZA



= 2500 pcs.



11402010 YA



UNICO

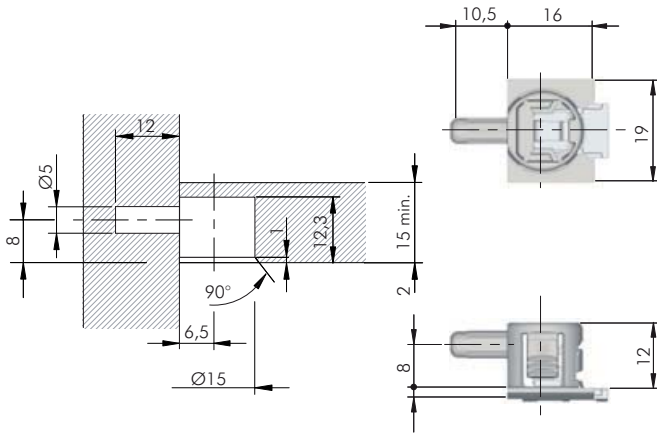

	= Ø 5 mm	+
	= UNI EN 14749/05	
ZA	EPg	= 2500 pcs.
10701010 YA	Cod. 10781	



INTEGRATO G

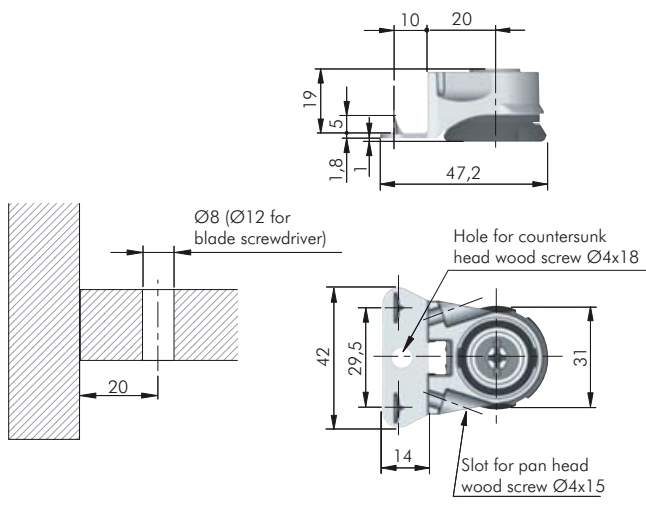

ADJUSTMENT 0 - 12 mm

= S6 mm
 = PZ2 - PH2
 = 1,6x10 mm

ZA EP
 = 300 pcs.

123

30106010 00





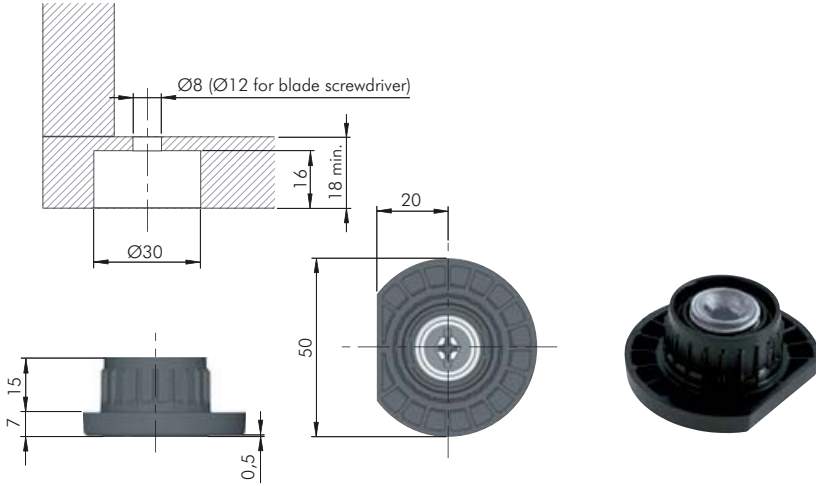

INTEGRATO Z ACCESSORY



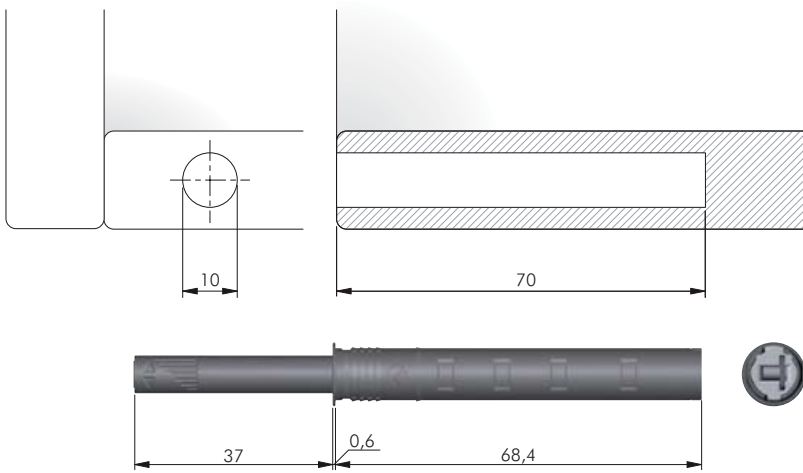

= S6 mm	= PZ2 - PH2	= 1,6x10 mm
ZA	EP	= 250 pcs.
30108010 EA	Cod. 03659	

K PUSH TECH









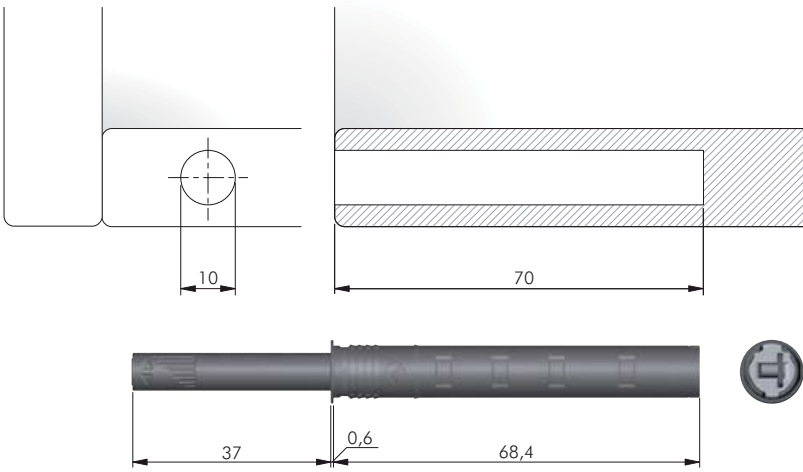

 ST
  EP
  = 100 pcs.

57008020 UJ



 ST
  EP
  SR
  = 100 pcs.

EE

57008040 UJ





ADAPTER HOUSING AND PLATE FOR LONG VERSION

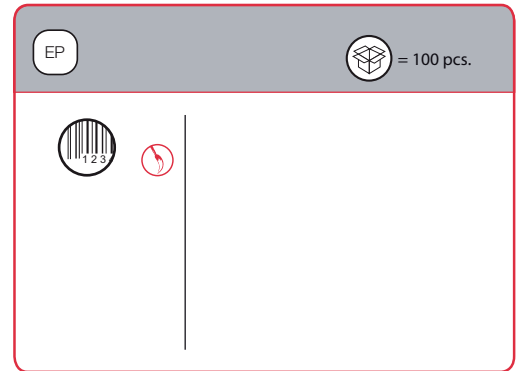
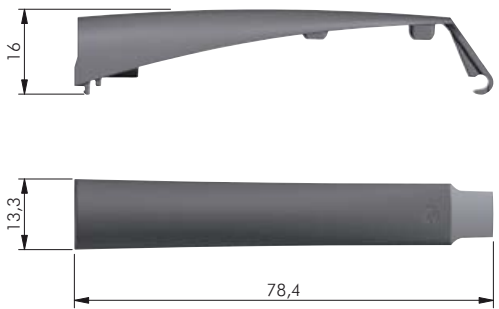

Conjunto Cod. C010001432

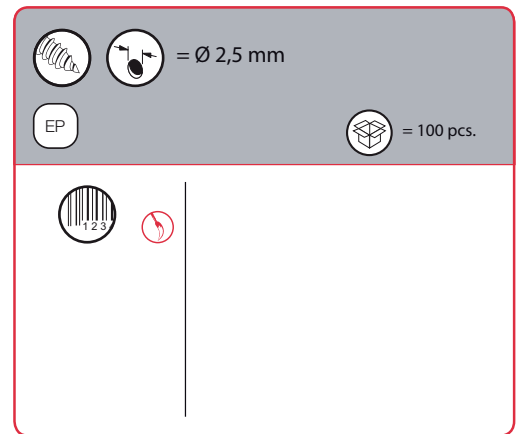
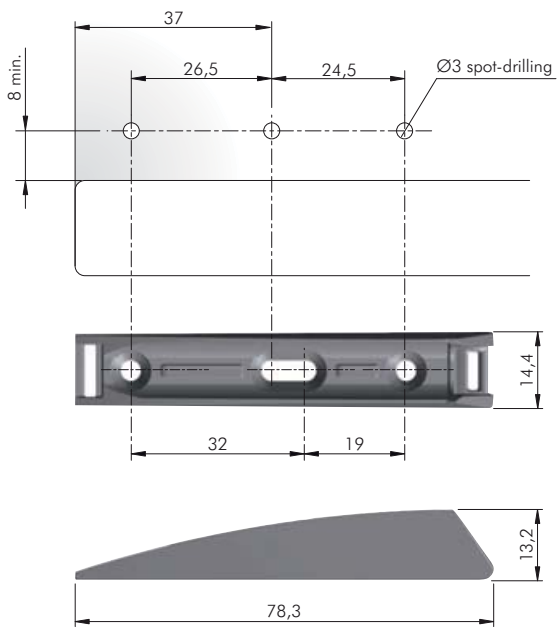



DOOR BUFFER BI-MATERIAL

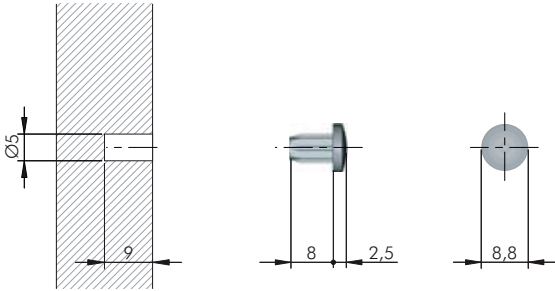

= Ø 5 mm	
	= 5000 pcs.
123	
23203010 ZZ	Cod. 10779

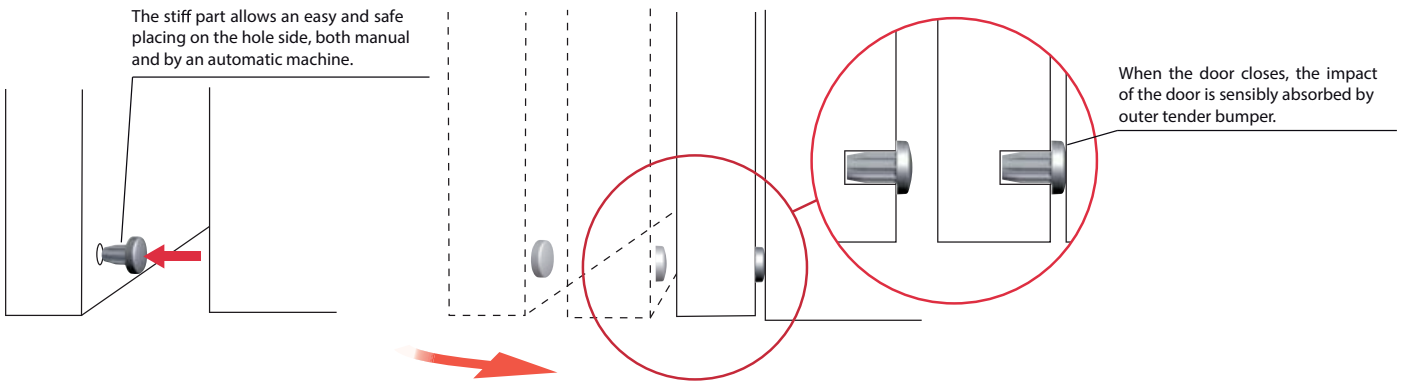



HERRAJES DE ANDALUCÍA

SEVILLA

Avda. de la Industria 15
Polg. Ind. Carretera Amarilla 41 007 SEVILLA
Tlf. 95 499 85 40
e-mail: info@herrajesandalucia.com
 690 866 531

ALMERÍA

C/ Sierra de Atalaya 19
Polg. Ind. La Jualda 04240 Viator ALMERÍA
Tlf. 950 30 60 98
e-mail: info@herrajesandalucia.com
 660 671 845

www.herrajesandalucia.com